

512 Kbit / 1 Mbit / 2 Mbit / 4 Mbit (x8)
Many-Time Programmable Flash
SST37VF512 / SST37VF010 / SST37VF020 / SST37VF040



Data Sheet

FEATURES:

- **Organized as 64K x8 / 128K x8 / 256K x8 / 512K x8**
- **2.7-3.6V Read Operation**
- **Superior Reliability**
 - Endurance: At least 1000 Cycles
 - Greater than 100 years Data Retention
- **Low Power Consumption:**
 - Active Current: 10 mA (typical)
 - Standby Current: 2 μ A (typical)
- **Fast Read Access Time:**
 - 70 ns
- **Latched Address and Data**
- **Fast Byte-Program Operation:**
 - Byte-Program Time: 15 μ s (typical)
 - Chip Program Time:
 - 1 seconds (typical) for SST37VF512
 - 2 seconds (typical) for SST37VF010
 - 4 seconds (typical) for SST37VF020
 - 8 seconds (typical) for SST37VF040
- **Electrical Erase Using Programmer**
 - Does not require UV source
 - Chip-Erase Time: 100 ms (typical)
- **CMOS I/O Compatibility**
- **JEDEC Standard Byte-wide Flash EEPROM Pinouts**
- **Packages Available**
 - 32-lead PLCC
 - 32-lead TSOP (8mm x 14mm)
 - 32-pin PDIP
 - Non-Pb (lead-free) packages available

PRODUCT DESCRIPTION

The SST37VF512/010/020/040 devices are 64K x8 / 128K x8 / 256K x8 / 512K x8 CMOS, Many-Time Programmable (MTP), low cost flash, manufactured with SST's proprietary, high performance CMOS SuperFlash technology. The split-gate cell design and thick-oxide tunneling injector attain better reliability and manufacturability compared with alternate approaches. The SST37VF512/010/020/040 can be electrically erased and programmed at least 1000 times using an external programmer, e.g., to change the contents of devices in inventory. The SST37VF512/010/020/040 have to be erased prior to programming. These devices conform to JEDEC standard pinouts for byte-wide flash memories.

Featuring high performance Byte-Program, the SST37VF512/010/020/040 provide a typical Byte-Program time of 15 μ s. Designed, manufactured, and tested for a wide spectrum of applications, these devices are offered with an endurance of at least 1000 cycles. Data retention is rated at greater than 100 years.

The SST37VF512/010/020/040 are suited for applications that require infrequent writes and low power nonvolatile storage. These devices will improve flexibility, efficiency, and performance while matching the low cost in nonvolatile applications that currently use UV-EPROMs, OTPs, and mask ROMs.

To meet surface mount and conventional through hole requirements, the SST37VF512/010/020/040 are offered in 32-lead PLCC, 32-lead TSOP, and 32-pin PDIP packages. See Figures 1, 2, and 3 for pin assignments.

Device Operation

The SST37VF512/010/020/040 devices are nonvolatile memory solutions that can be used instead of standard flash devices if in-system programmability is not required. It is functionally (Read) and pin compatible with industry standard flash products. The device supports electrical Erase operation via an external programmer.

Read

The Read operation of the SST37VF512/010/020/040 is controlled by CE# and OE#. Both CE# and OE# have to be low for the system to obtain data from the outputs. Once the address is stable, the address access time is equal to the delay from CE# to output (T_{CE}). Data is available at the output after a delay of TOE from the falling edge of OE#, assuming the CE# pin has been low and the addresses have been stable for at least $T_{CE}-T_{OE}$. When the CE# pin is high, the chip is deselected and a standby current of only 2 μ A (typical) is consumed. OE# is the output control and is used to gate data from the output pins. The data bus is in high impedance state when either CE# or OE# is V_{IH} . Refer to Figure 4 for the timing diagram.



512 Kbit / 1 Mbit / 2 Mbit / 4 Mbit Many-Time Programmable Flash SST37VF512 / SST37VF010 / SST37VF020 / SST37VF040

Data Sheet

Byte-Program Operation

The SST37VF512/010/020/040 are programmed by using an external programmer. The programming mode is activated by asserting 11.4-12.6V on OE# pin and V_{IL} on CE# pin. The device is programmed using a single pulse (WE# pin low) of 15 μs per byte. Using the MTP programming algorithm, the Byte-Program process continues byte-by-byte until the entire chip has been programmed. Refer to Figure 10 for the flowchart and Figure 6 for the timing diagram.

Chip-Erase Operation

The only way to change a data from a “0” to “1” is by electrical erase that changes every bit in the device to “1”. The SST37VF512/010/020/040 use an electrical Chip-Erase operation. The entire chip can be erased in 100 ms (WE# pin low). In order to activate erase mode, the 11.4-12.6V is applied to OE# and A₉ pins while CE# is low. All other address and data pins are “don’t care”. The falling edge of WE# will start the Chip-Erase operation. Once the chip has been erased, all bytes must be verified for FFH. Refer to Figure 9 for the flowchart and Figure 5 for the timing diagram.

Product Identification Mode

The Product Identification mode identifies the devices as SST37VF512, SST37VF010, SST37VF020, and SST37VF040 and manufacturer as SST. This mode may be accessed by the hardware method. To activate this mode, the programming equipment must force V_H (11.4-12.6V) on address A₉. Two identifier bytes may then be sequenced from the device outputs by toggling address line A₀. For details, see Table 3 for hardware operation.

TABLE 1: PRODUCT IDENTIFICATION

	Address	Data
Manufacturer's ID	0000H	BFH
Device ID		
SST37VF512	0001H	C4H
SST37VF010	0001H	C5H
SST37VF020	0001H	C6H
SST37VF040	0001H	C2H

T1.2 1151

Design Considerations

The SST37VF512/010/020/040 should have a 0.1 μF ceramic high frequency, low inductance capacitor connected between V_{DD} and GND. This capacitor should be placed as close to the package terminals as possible.

OE# and A₉ must remain stable at V_H for the entire duration of an Erase operation. OE# must remain stable at V_H for the entire duration of the Program operation.

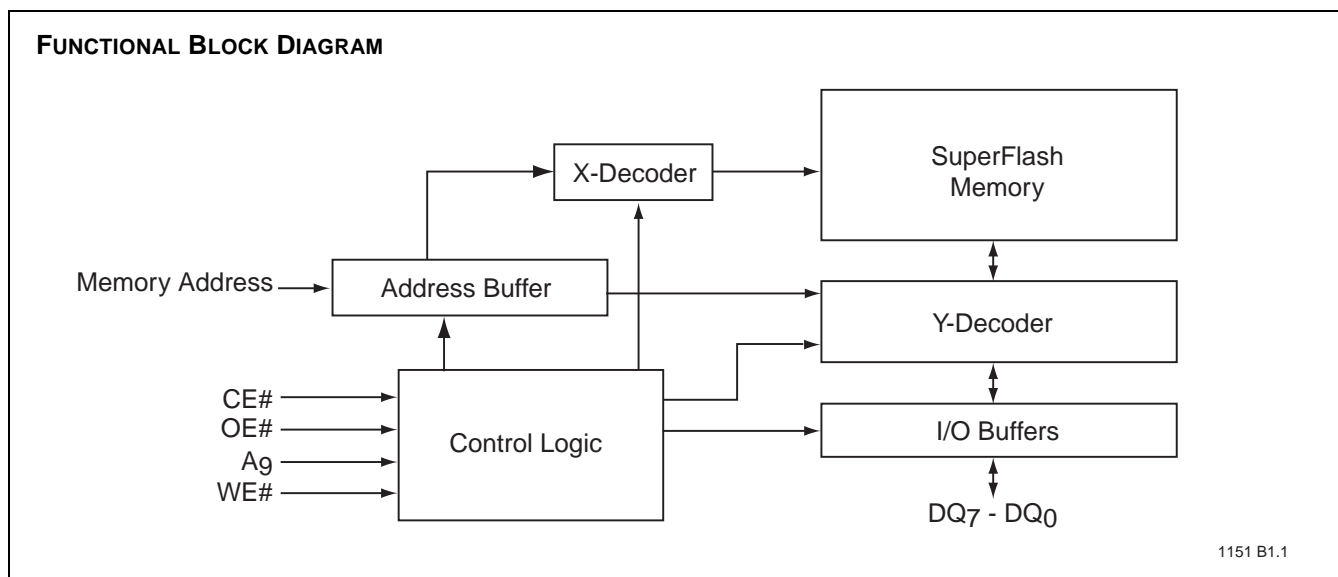

512 Kbit / 1 Mbit / 2 Mbit / 4 Mbit Many-Time Programmable Flash SST37VF512 / SST37VF010 / SST37VF020 / SST37VF040



Data Sheet

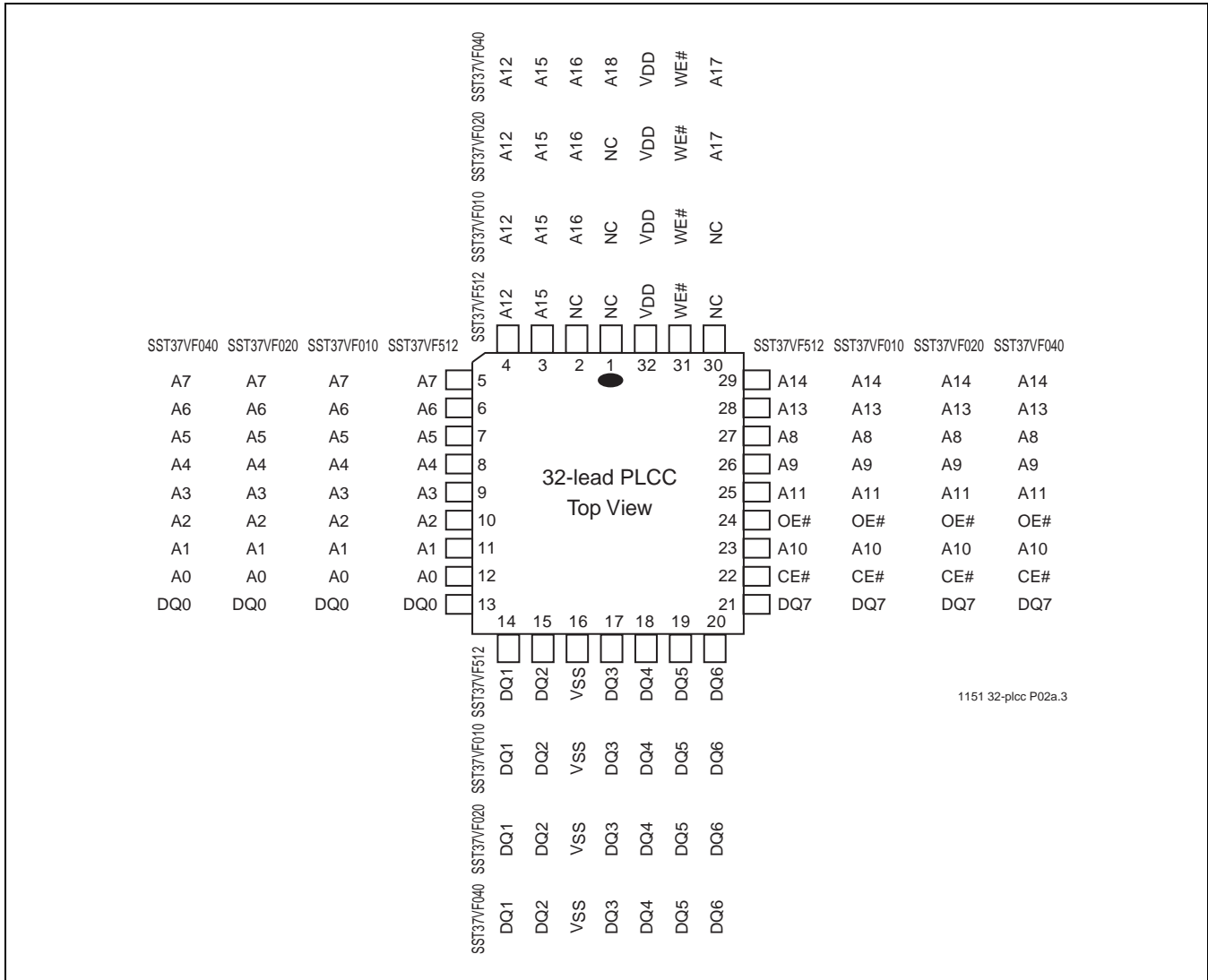

FIGURE 1: PIN ASSIGNMENTS FOR 32-LEAD PLCC

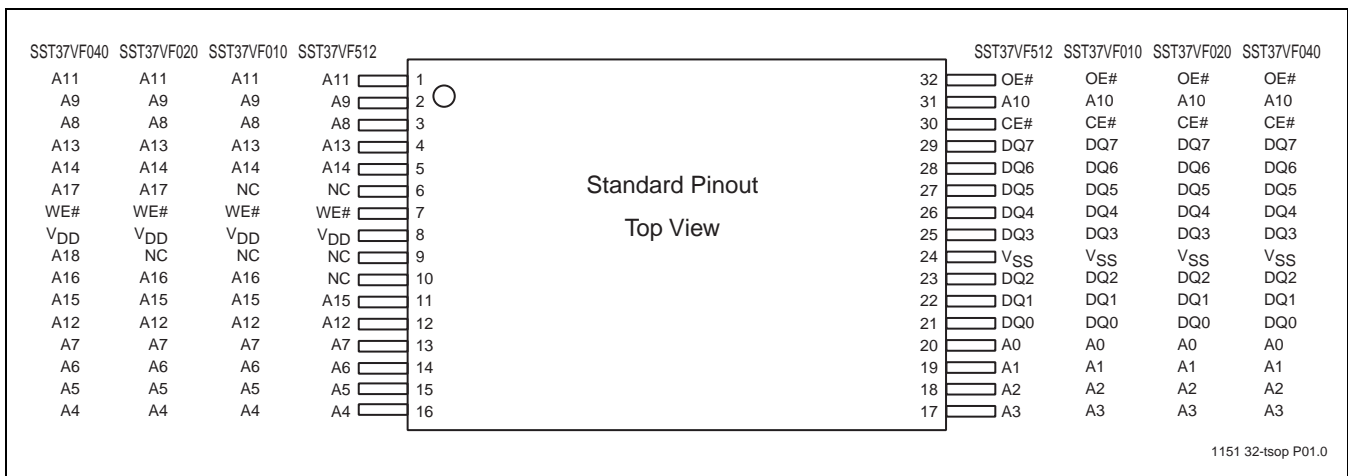

FIGURE 2: PIN ASSIGNMENTS FOR 32-LEAD TSOP (8MM X 14MM)



512 Kbit / 1 Mbit / 2 Mbit / 4 Mbit Many-Time Programmable Flash SST37VF512 / SST37VF010 / SST37VF020 / SST37VF040

Data Sheet

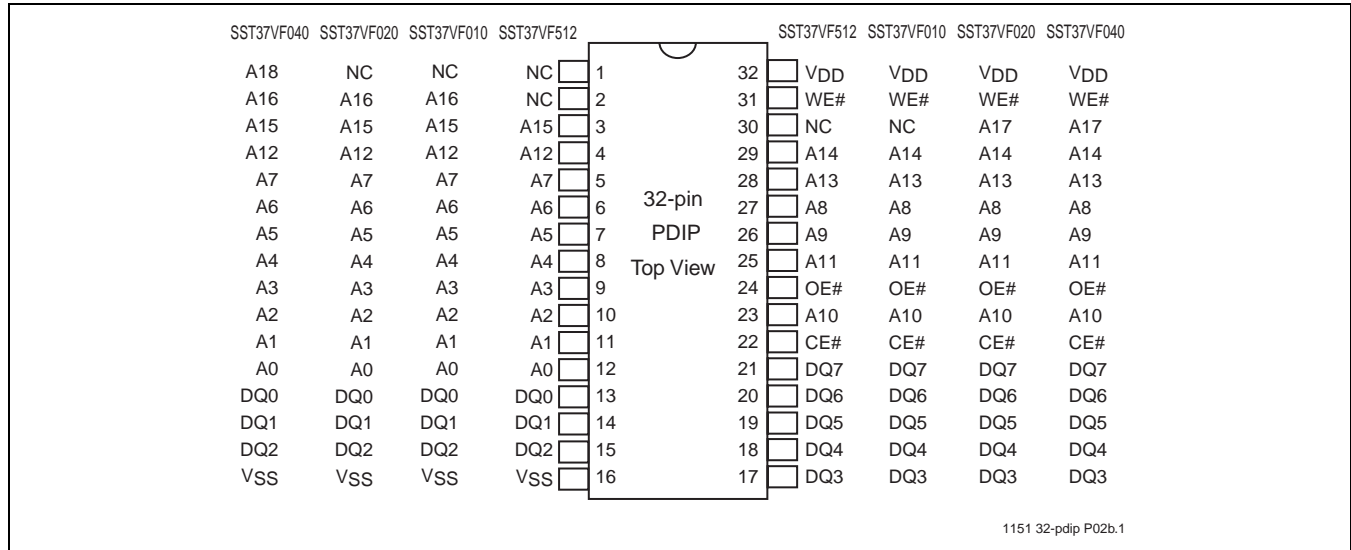

FIGURE 3: PIN ASSIGNMENTS FOR 32-PIN PDIP

TABLE 2: PIN DESCRIPTION

Symbol	Pin Name	Functions
$A_{MS}^1-A_0$	Address Inputs	To provide memory addresses.
DQ_7-DQ_0	Data Input/output	To output data during Read cycles and receive input data during Program cycles. The outputs are in tri-state when OE# or CE# is high.
CE#	Chip Enable	To activate the device when CE# is low.
WE#	Write Enable	To program or erase (WE# = V_{IL} pulse during Program or Erase)
OE#	Output Enable	To gate the data output buffers during Read operation when low
V_{DD}	Power Supply	To provide 3.0V supply (2.7-3.6V)
V_{SS}	Ground	
NC	No Connection	Unconnected pins.

T2.1 1151

- A_{MS} = Most significant address
 $A_{MS} = A_{15}$ for SST37VF512, A_{16} for SST37VF010, A_{17} for SST37VF020, and A_{18} for SST37VF040

TABLE 3: OPERATION MODES SELECTION

Mode	CE#	WE#	A_9	OE#	DQ	Address
Read	V_{IL}	V_{IH}	A_{IN}	V_{IL}	D_{OUT}	A_{IN}
Output Disable	V_{IL}	X	X	V_{IH}	High Z	A_{IN}
Standby	V_{IH}	X	X	X	High Z	X
Chip-Erase	V_{IL}	V_{IL}	V_H	V_H	High Z	X
Byte-Program	V_{IL}	V_{IL}	A_{IN}	V_H	D_{IN}	A_{IN}
Program/Erase Inhibit	X	V_{IH}	X	X	High Z	X
	X	X	X	V_{IL} or V_{IH}	High Z/ D_{OUT}	X
Product Identification	V_{IL}	V_{IH}	V_H	V_{IL}	Manufacturer's ID (BFH) Device ID ¹	$A_{MS}^2 - A_1 = V_{IL}, A_0 = V_{IL}$ $A_{MS}^2 - A_1 = V_{IL}, A_0 = V_{IH}$

T3.2 1151

- Device ID = C4H for SST37VF512, C5H for SST37VF020, C6H for SST37VF020, and C2H for SST37VF040
- A_{MS} = Most significant address
 $A_{MS} = A_{15}$ for SST37VF512, A_{16} for SST37VF010, A_{17} for SST37VF020, and A_{18} for SST37VF040

Note: X = V_{IL} or V_{IH} (or V_H in case of OE# and A_9)
 $V_H = 11.4-12.6V$



512 Kbit / 1 Mbit / 2 Mbit / 4 Mbit Many-Time Programmable Flash

SST37VF512 / SST37VF010 / SST37VF020 / SST37VF040

Data Sheet

Absolute Maximum Stress Ratings (Applied conditions greater than those listed under “Absolute Maximum Stress Ratings” may cause permanent damage to the device. This is a stress rating only and functional operation of the device at these conditions or conditions greater than those defined in the operational sections of this data sheet is not implied. Exposure to absolute maximum stress rating conditions may affect device reliability.)

Temperature Under Bias	-55°C to +125°C
Storage Temperature	-65°C to +150°C
D. C. Voltage on Any Pin to Ground Potential	-0.5V to $V_{DD}+0.5V$
Transient Voltage (<20 ns) on Any Pin to Ground Potential	-2.0V to $V_{DD}+2.0V$
Voltage on A ₉ Pin to Ground Potential	-0.5V to 13.2V
Package Power Dissipation Capability (T _A = 25°C)	1.0W
Through Hole Lead Soldering Temperature (10 Seconds)	300°C
Surface Mount Solder Reflow Temperature:	“with-Pb” units ¹ : 240°C for 3 seconds
	“non-Pb” units: 260°C for 3 seconds
Output Short Circuit Current ²	50 mA

1. Certain “with-Pb” package types are capable of 260°C for 3 seconds; please consult the factory for the latest information.
 2. Outputs shorted for no more than one second. No more than one output shorted at a time.

OPERATING RANGE

Range	Ambient Temp	V _{DD}
Commercial	0°C to +70°C	2.7-3.6V

AC CONDITIONS OF TEST

Input Rise/Fall Time	5 ns
Output Load	C _L = 100 pF
See Figures 7 and 8	

TABLE 4: READ MODE DC OPERATING CHARACTERISTICS V_{DD}=2.7-3.6V (T_A = 0°C to +70°C (Commercial))

Symbol	Parameter	Limits			Test Conditions
		Min	Max	Units	
I _{DD}	V _{DD} Read Current		12	mA	Address input=V _{ILT} /V _{IHT} , at f=1/T _{RC} Min V _{DD} =V _{DD} Max CE#=V _{IL} , OE#=V _{IHT} , all I/Os open
I _{SB}	Standby V _{DD} Current		15	μA	CE#=V _{IHC} , V _{DD} =V _{DD} Max
I _{LI}	Input Leakage Current		1	μA	V _{IN} =GND to V _{DD} , V _{DD} =V _{DD} Max
I _{LO}	Output Leakage Current		10	μA	V _{OUT} =GND to V _{DD} , V _{DD} =V _{DD} Max
V _{IL}	Input Low Voltage		0.8	V	V _{DD} =V _{DD} Min
V _{IH}	Input High Voltage	0.7 V _{DD}		V	V _{DD} =V _{DD} Max
V _{IHC}	Input High Voltage (CMOS)	V _{DD} -0.3		V	V _{DD} =V _{DD} Max
V _{OL}	Output Low Voltage		0.2	V	I _{OL} =100 μA, V _{DD} =V _{DD} Min
V _{OH}	Output High Voltage	V _{DD} -0.3		V	I _{OH} =-100 μA, V _{DD} =V _{DD} Min
I _H	Supervoltage Current for A ₉		200	μA	CE#=OE#=V _{IL} , A ₉ =V _H Max

T4.6 1151



512 Kbit / 1 Mbit / 2 Mbit / 4 Mbit Many-Time Programmable Flash

SST37VF512 / SST37VF010 / SST37VF020 / SST37VF040

Data Sheet

TABLE 5: PROGRAM/ERASE DC OPERATING CHARACTERISTICS $V_{DD}=2.7-3.6V$ ($T_A = 25^\circ C \pm 5^\circ C$)

Symbol	Parameter	Limits			Test Conditions
		Min	Max	Units	
I_{DD}	V_{DD} Erase or Program Current		20	mA	$CE\#=V_{IL}$, $OE\#=V_H$, $V_{DD}=V_{DD} \text{ Max}$, $WE\#=V_{IL}$
I_{LI}	Input Leakage Current		1	μA	$V_{IN}=GND$ to V_{DD} , $V_{DD}=V_{DD} \text{ Max}$
I_{LO}	Output Leakage Current		10	μA	$V_{OUT}=GND$ to V_{DD} , $V_{DD}=V_{DD} \text{ Max}$
V_H	Supervoltage for A_9 and $OE\#$	11.4	12.6	V	$OE\#=V_H \text{ Max}$, $A_9=V_H \text{ Max}$, $V_{DD}=V_{DD} \text{ Max}$, $CE\#=V_{IL}$ $CE\#=V_{IL}$, $OE\#=11.4-12.6V$, $V_{DD}=V_{DD} \text{ Max}$, $WE\#=V_{IL}$
I_{HA9}	Supervoltage Current for A_9		200	μA	
$I_{HOE\#}$	Supervoltage Current for $OE\#$		3	mA	

T5.2 1151

TABLE 6: RECOMMENDED SYSTEM POWER-UP TIMINGS

Symbol	Parameter	Minimum	Units
$T_{PU-READ}^1$	Power-up to Read Operation	100	μs
$T_{PU-WRITE}^1$	Power-up to Write Operation	100	μs

T6.1 1151

1. This parameter is measured only for initial qualification and after a design or process change that could affect this parameter.

TABLE 7: CAPACITANCE ($T_A = 25^\circ C$, $f=1 \text{ Mhz}$, other pins open)

Parameter	Description	Test Condition	Maximum
$C_{I/O}^1$	I/O Pin Capacitance	$V_{I/O} = 0V$	12 pF
C_{IN}^1	Input Capacitance	$V_{IN} = 0V$	6 pF

T7.0 1151

1. This parameter is measured only for initial qualification and after a design or process change that could affect this parameter.

TABLE 8: RELIABILITY CHARACTERISTICS

Symbol	Parameter	Minimum Specification	Units	Test Method
N_{END}^1	Endurance	10,000	Cycles	JEDEC Standard A117
T_{DR}^1	Data Retention	100	Years	JEDEC Standard A103
I_{LTH}^1	Latch Up	$100 + I_{DD}$	mA	JEDEC Standard 78

T8.3 1151

1. This parameter is measured only for initial qualification and after a design or process change that could affect this parameter.



AC CHARACTERISTICS

TABLE 9: READ CYCLE TIMING PARAMETERS $V_{DD} = 2.7-3.6V$ ($T_A = 0^\circ C$ to $+70^\circ C$ (Commercial))

Symbol	Parameter	SST37VF512-70 SST37VF010-70 SST37VF020-70 SST37VF040-70		Units
		Min	Max	
T_{RC}	Read Cycle Time	70		ns
T_{CE}	Chip Enable Access Time		70	ns
T_{AA}	Address Access Time		70	ns
T_{OE}	Output Enable Access Time		35	ns
T_{CLZ}^1	CE# Low to Active Output	0		ns
T_{OLZ}^1	OE# Low to Active Output	0		ns
T_{CHZ}^1	CE# High to High-Z Output		25	ns
T_{OHZ}^1	OE# High to High-Z Output		25	ns
T_{OH}^1	Output Hold from Address Change	0		ns

T9.3 1151

1. This parameter is measured only for initial qualification and after a design or process change that could affect this parameter.

TABLE 10: PROGRAM/ERASE CYCLE TIMING PARAMETERS $V_{DD} = 2.7-3.6V$ ($T_A = 25^\circ C \pm 5^\circ C$)

Symbol	Parameter	Min	Max	Units
T_{BP}	Byte-Program Time		20	μs
T_{CES}	CE# Setup Time	1		μs
T_{CEH}	CE# Hold Time	1		μs
T_{AS}	Address Setup Time	1		μs
T_{AH}	Address Hold Time	1		μs
T_{DS}	Data Setup Time	1		μs
T_{DH}	Data Hold Time	1		μs
T_{PRT}	OE# Rise Time for Program and Erase	50		ns
T_{VPS}	OE# Setup Time for Program and Erase	1		μs
T_{VPH}	OE# Hold Time for Program and Erase	1		μs
T_{PW}	WE# Program Pulse Width	15	25	μs
T_{EW}	WE# Erase Pulse Width	100	200	ms
T_{VR}	OE#/A ₉ Recovery Time for Erase	1		μs
T_{ART}	A ₉ Rise Time to 12V during Erase	50		ns
T_{A9S}	A ₉ Setup Time during Erase	1		μs
T_{A9H}	A ₉ Hold Time during Erase	1		μs

T10.1 1151



512 Kbit / 1 Mbit / 2 Mbit / 4 Mbit Many-Time Programmable Flash
 SST37VF512 / SST37VF010 / SST37VF020 / SST37VF040

Data Sheet

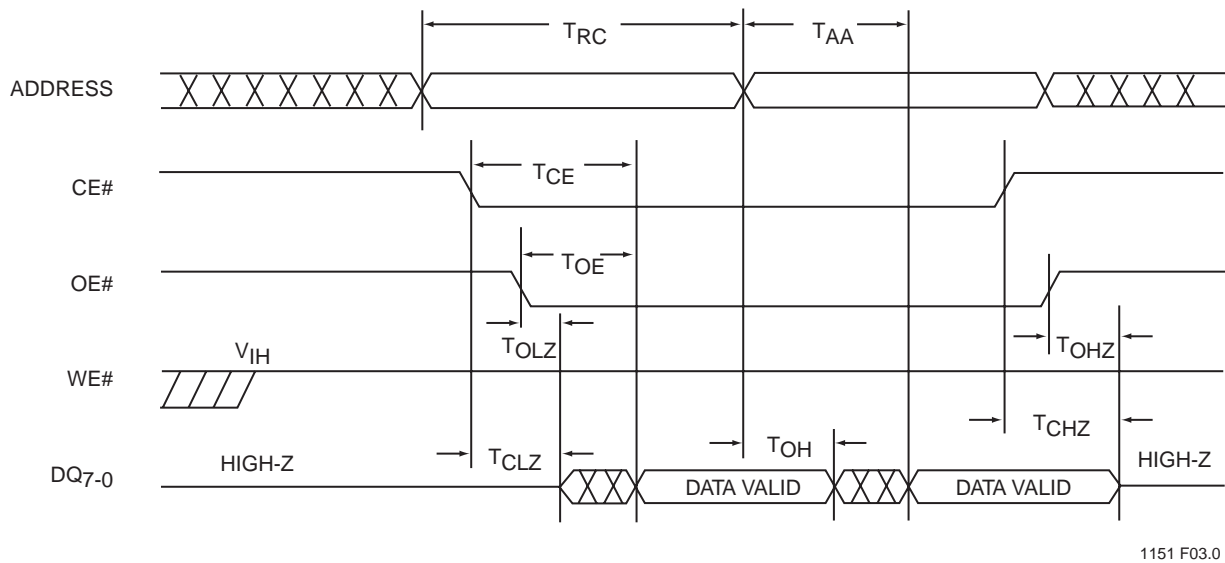

1151 F03.0

FIGURE 4: READ CYCLE TIMING DIAGRAM

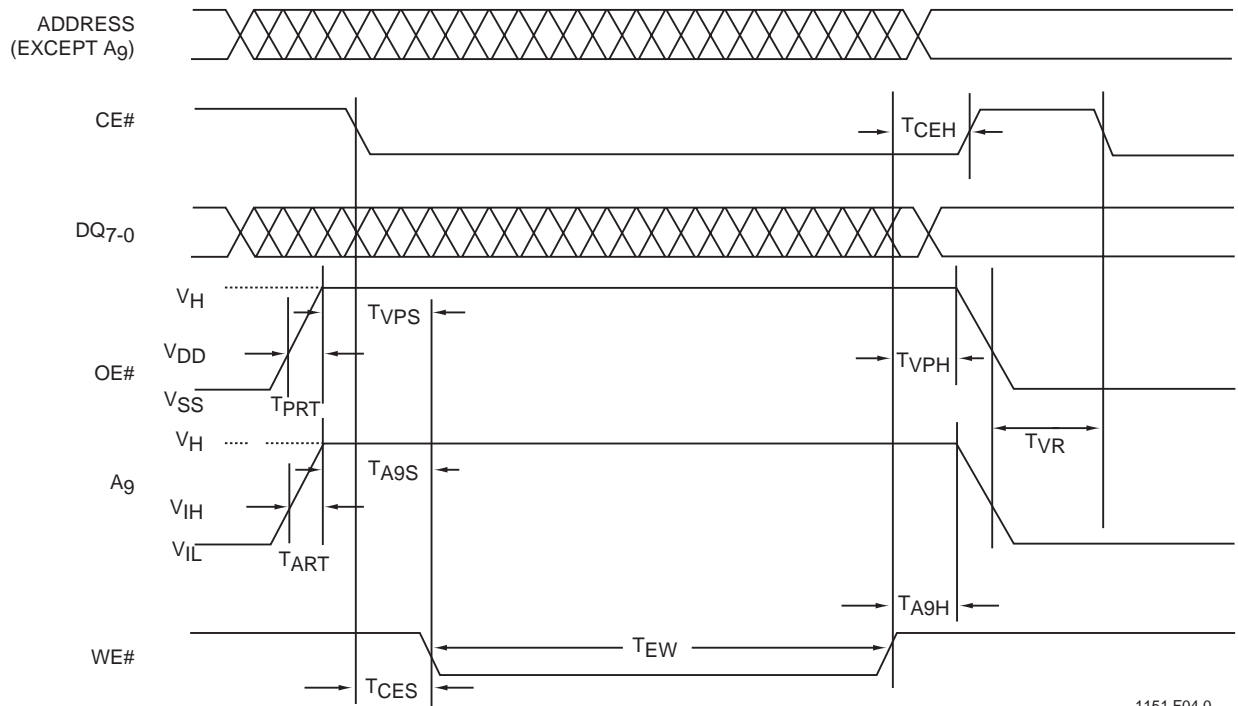

1151 F04.0

FIGURE 5: CHIP-ERASE TIMING DIAGRAM



512 Kbit / 1 Mbit / 2 Mbit / 4 Mbit Many-Time Programmable Flash SST37VF512 / SST37VF010 / SST37VF020 / SST37VF040

Data Sheet

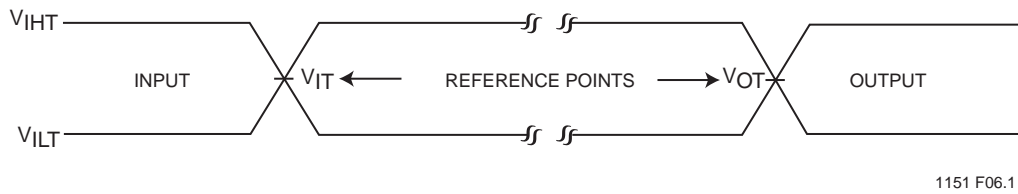

AC test inputs are driven at V_{IHT} ($0.9 V_{DD}$) for a logic "1" and V_{ILT} ($0.1 V_{DD}$) for a logic "0". Measurement reference points for inputs and outputs are V_{IT} ($0.5 V$) and V_{OT} ($0.5 V_{DD}$). Input rise and fall times ($10\% \leftrightarrow 90\%$) are <5 ns.

Note: V_{IT} - V_{INPUT} Test
 V_{OT} - V_{OUTPUT} Test
 V_{IHT} - V_{INPUT} HIGH Test
 V_{ILT} - V_{INPUT} LOW Test

FIGURE 7: AC INPUT/OUTPUT REFERENCE WAVEFORMS

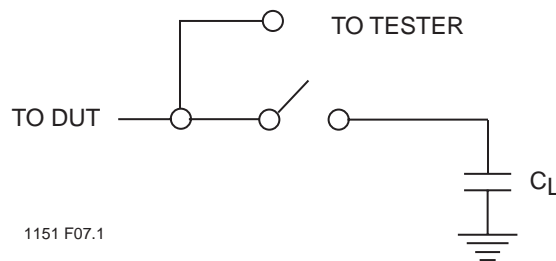
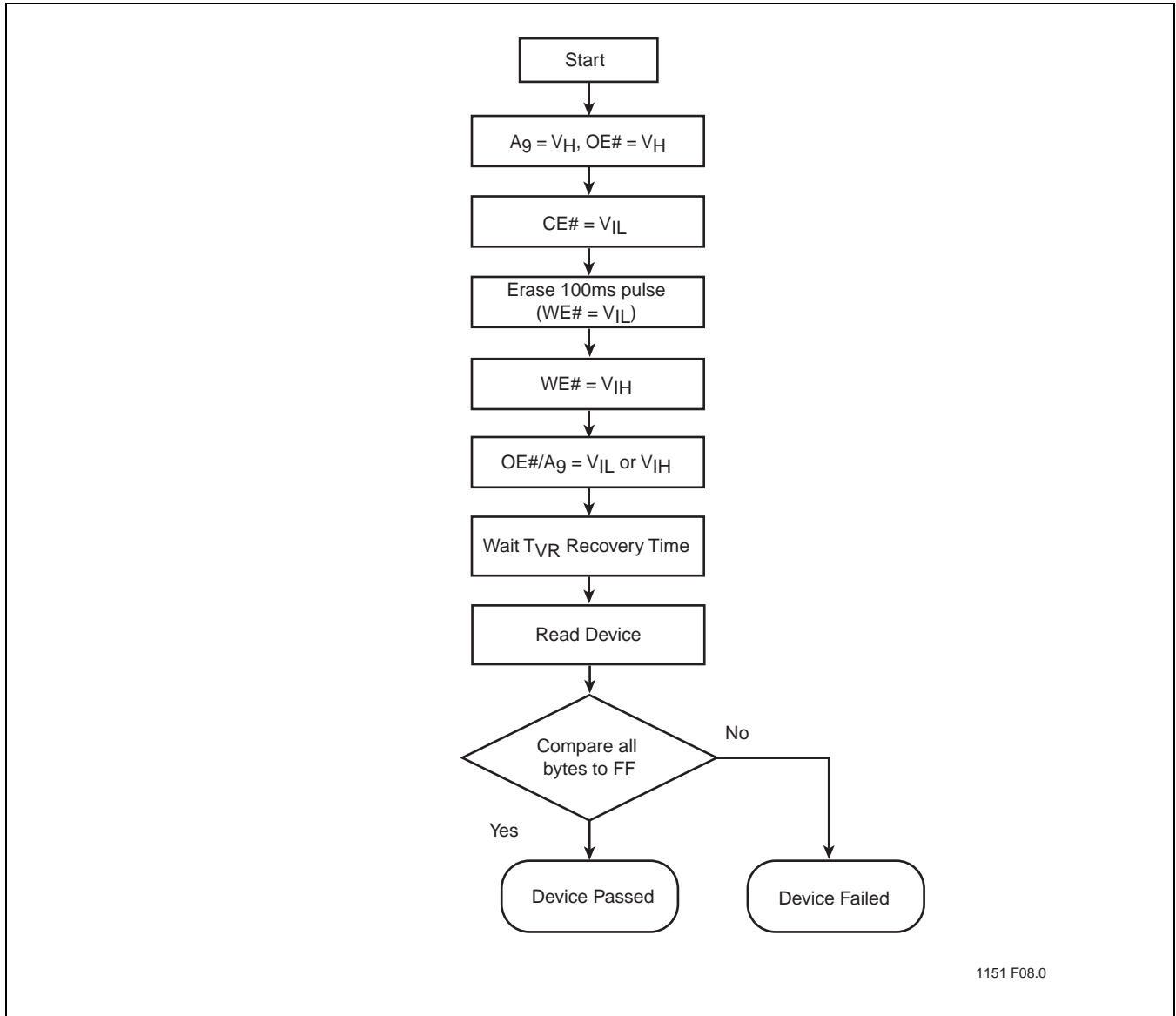

FIGURE 8: A TEST LOAD EXAMPLE



1151 F08.0

FIGURE 9: CHIP-ERASE ALGORITHM



512 Kbit / 1 Mbit / 2 Mbit / 4 Mbit Many-Time Programmable Flash
SST37VF512 / SST37VF010 / SST37VF020 / SST37VF040

Data Sheet

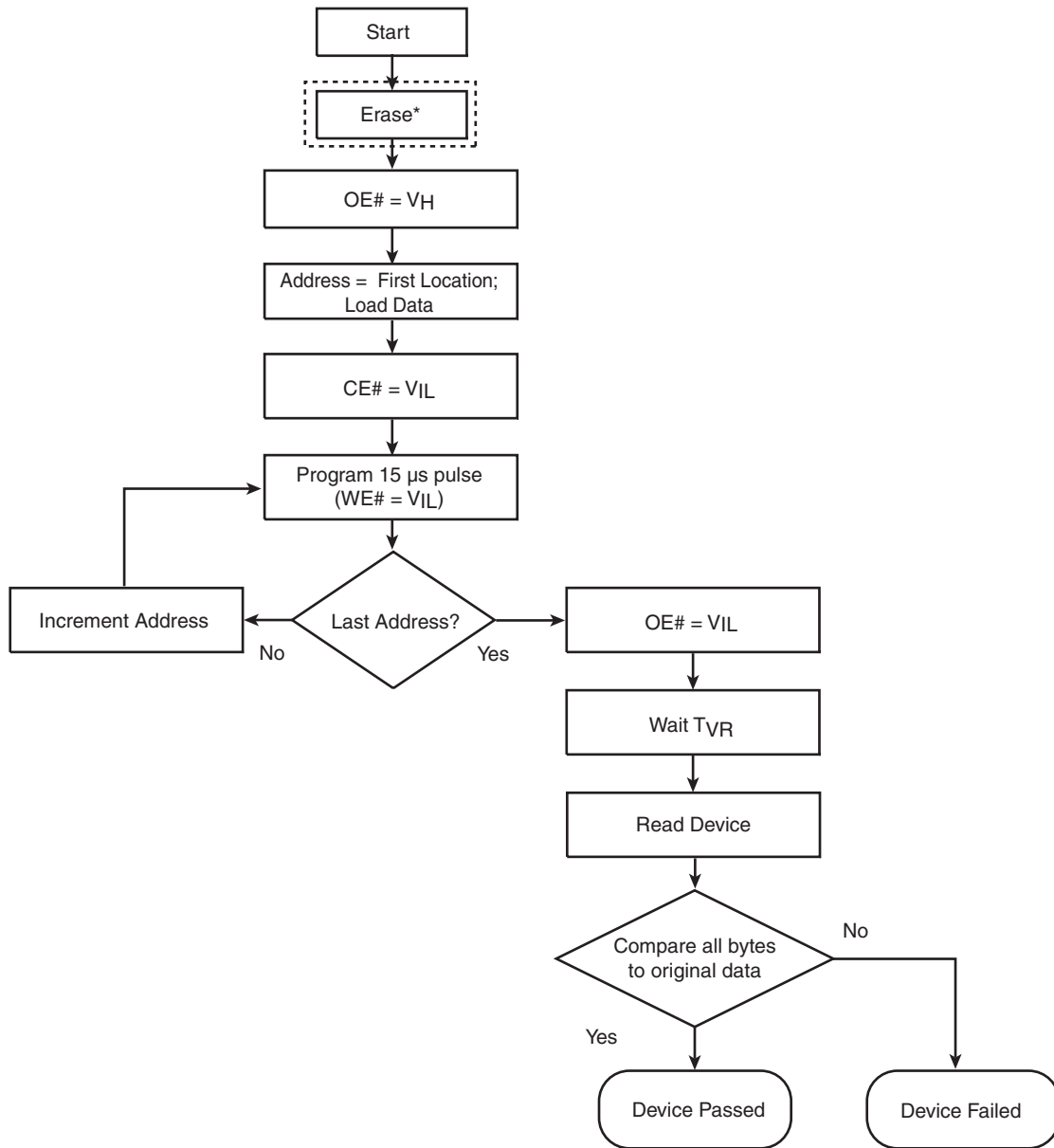

1151 F09.2

*See Figure 9

FIGURE 10: BYTE-PROGRAM ALGORITHM

512 Kbit / 1 Mbit / 2 Mbit / 4 Mbit Many-Time Programmable Flash
SST37VF512 / SST37VF010 / SST37VF020 / SST37VF040



Data Sheet

PRODUCT ORDERING INFORMATION

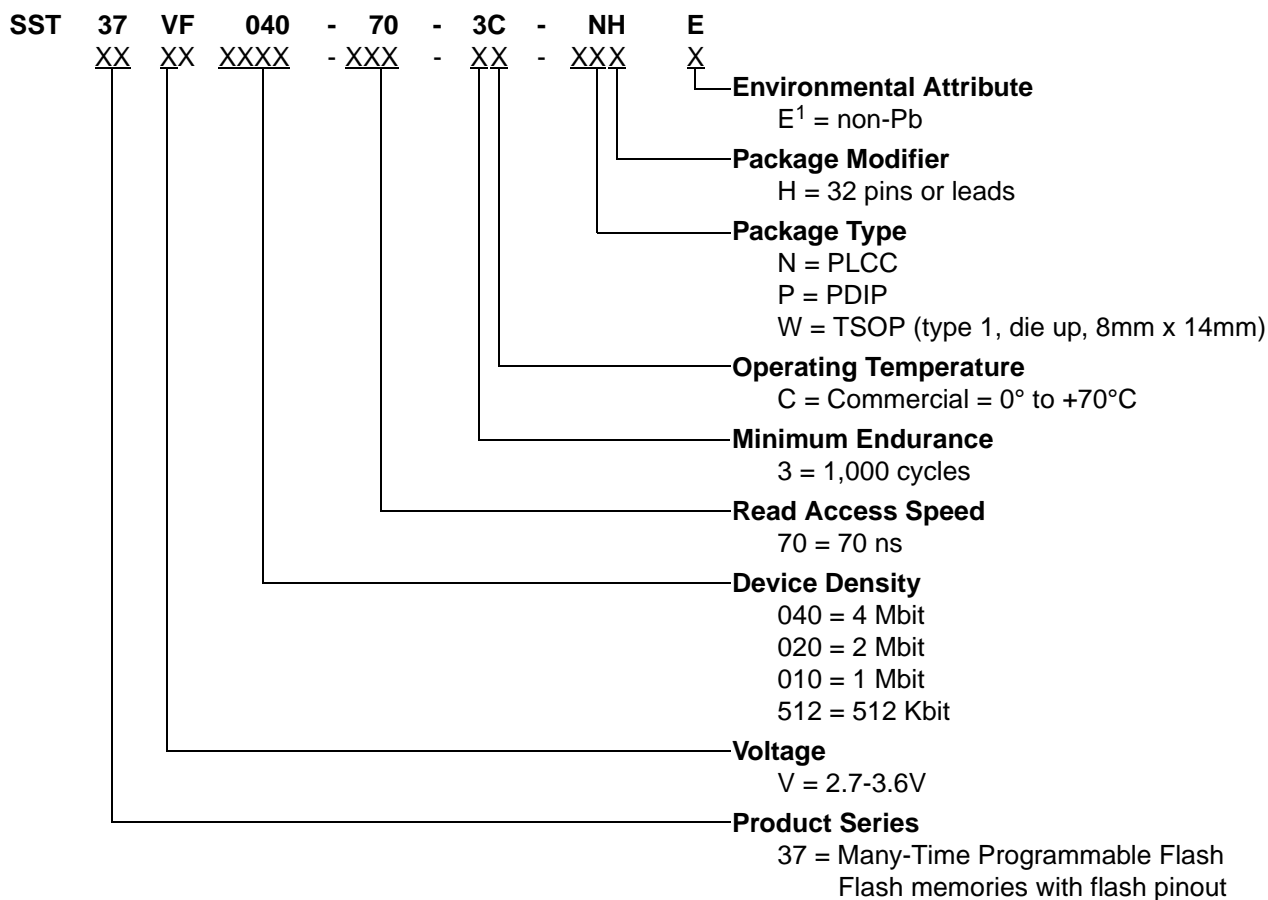

1. Environmental suffix "E" denotes non-Pb solder.
 SST non-Pb solder devices are "RoHS Compliant".



512 Kbit / 1 Mbit / 2 Mbit / 4 Mbit Many-Time Programmable Flash SST37VF512 / SST37VF010 / SST37VF020 / SST37VF040

Data Sheet

Valid combinations for SST37VF512

SST37VF512-70-3C-NH* SST37VF512-70-3C-WH* SST37VF512-70-3C-PH*
SST37VF512-70-3C-NHE* SST37VF512-70-3C-WHE*

Valid combinations for SST37VF010

SST37VF010-70-3C-NH SST37VF010-70-3C-WH SST37VF010-70-3C-PH
SST37VF010-70-3C-NHE SST37VF010-70-3C-WHE SST37VF010-70-3C-PHE

Valid combinations for SST37VF020

SST37VF020-70-3C-NH SST37VF020-70-3C-WH SST37VF020-70-3C-PH
SST37VF020-70-3C-NHE SST37VF020-70-3C-WHE SST37VF020-70-3C-PHE

Valid combinations for SST37VF040

SST37VF040-70-3C-NH SST37VF040-70-3C-WH SST37VF040-70-3C-PH
SST37VF040-70-3C-NHE SST37VF040-70-3C-WHE SST37VF040-70-3C-PHE

Note: Valid combinations are those products in mass production or will be in mass production. Consult your SST sales representative to confirm availability of valid combinations and to determine availability of new combinations.

* Not recommended for new designs.

512 Kbit / 1 Mbit / 2 Mbit / 4 Mbit Many-Time Programmable Flash
SST37VF512 / SST37VF010 / SST37VF020 / SST37VF040



Data Sheet

PACKAGING DIAGRAMS

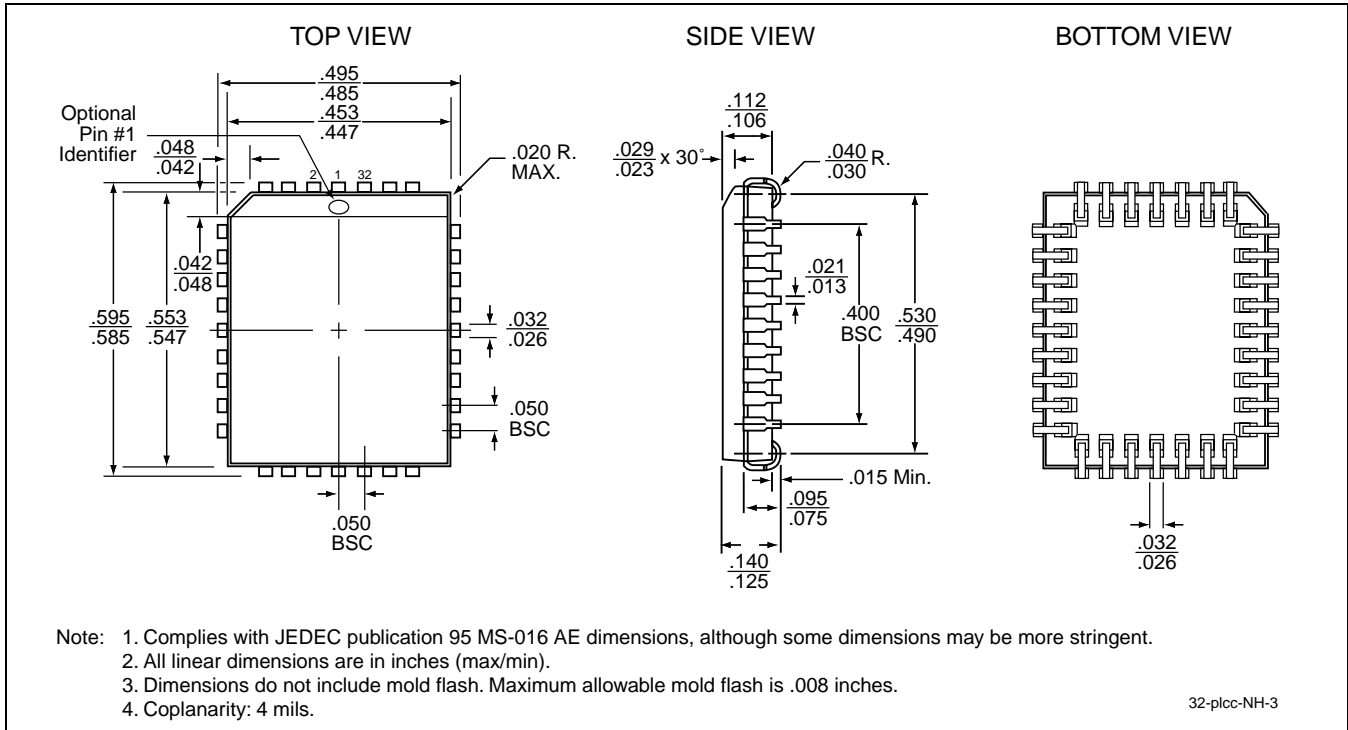

32-LEAD PLASTIC LEAD CHIP CARRIER (PLCC)
SST PACKAGE CODE: NH



512 Kbit / 1 Mbit / 2 Mbit / 4 Mbit Many-Time Programmable Flash SST37VF512 / SST37VF010 / SST37VF020 / SST37VF040

Data Sheet

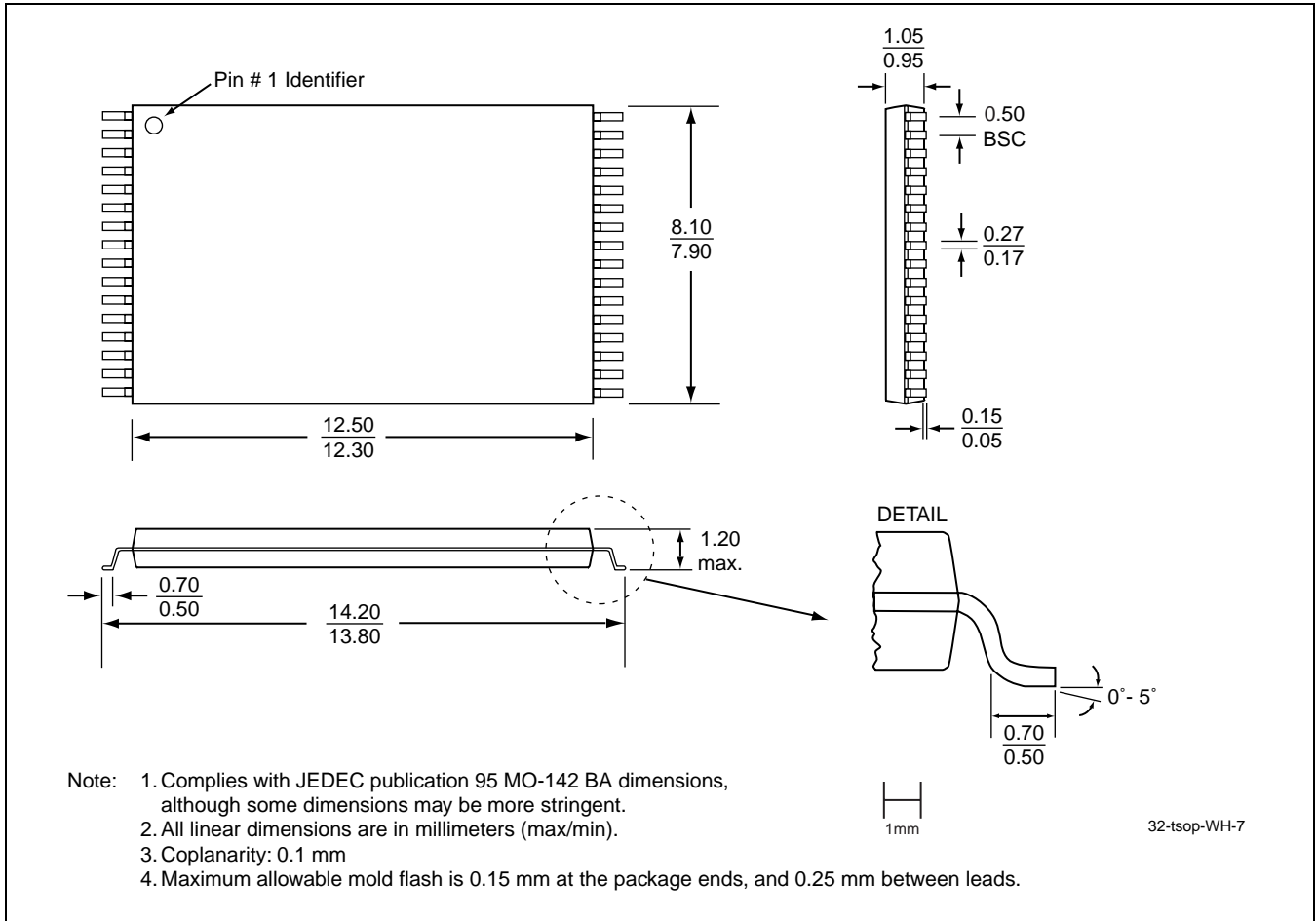

32-LEAD THIN SMALL OUTLINE PACKAGE (TSOP) 8MM X 14MM
SST PACKAGE CODE: WH

512 Kbit / 1 Mbit / 2 Mbit / 4 Mbit Many-Time Programmable Flash
 SST37VF512 / SST37VF010 / SST37VF020 / SST37VF040



Data Sheet

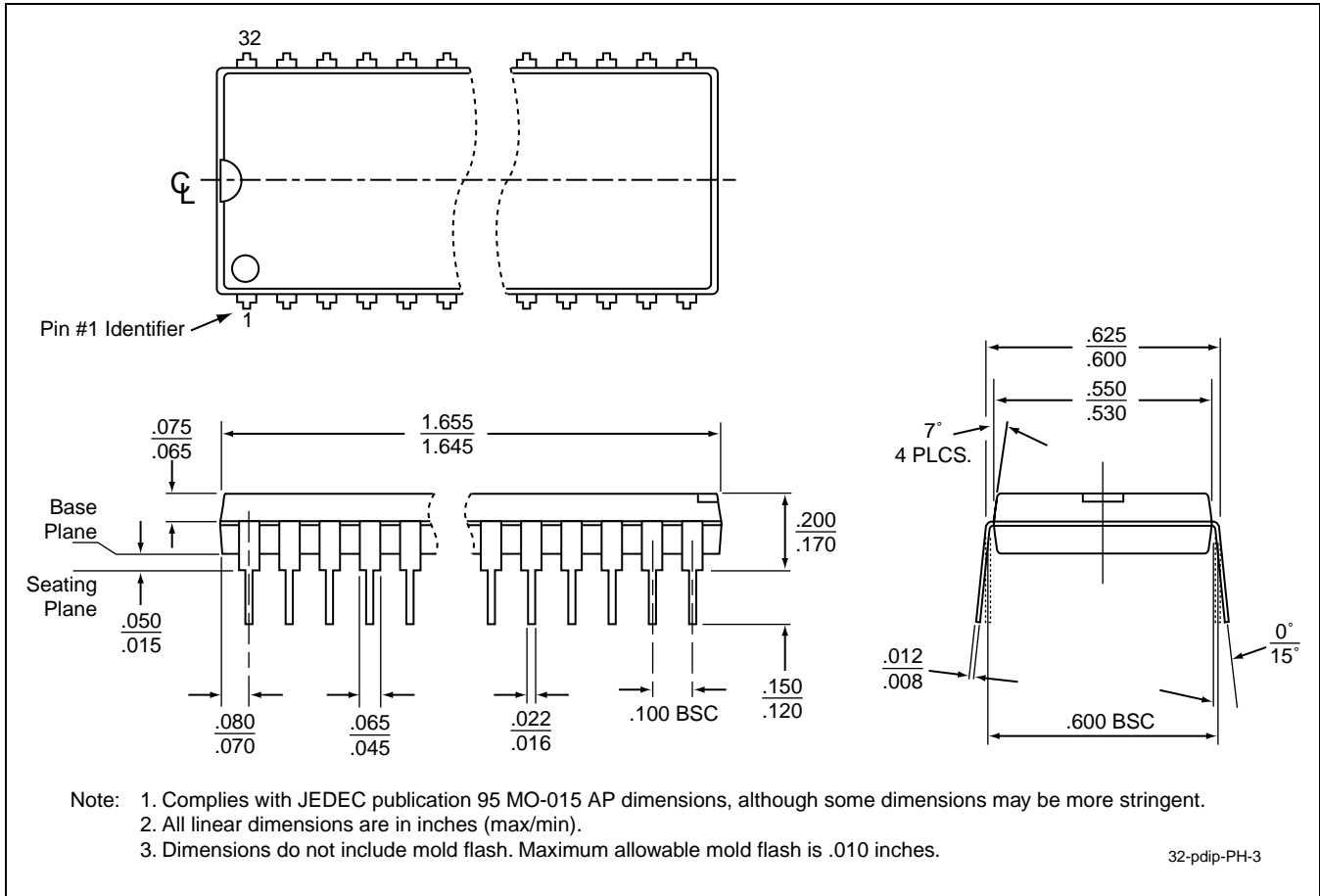

32-PIN PLASTIC DUAL IN-LINE PINS (PDIP)
SST PACKAGE CODE: PH



512 Kbit / 1 Mbit / 2 Mbit / 4 Mbit Many-Time Programmable Flash SST37VF512 / SST37VF010 / SST37VF020 / SST37VF040

Data Sheet

TABLE 11: REVISION HISTORY

Number	Description	Date
02	<ul style="list-style-type: none">• 2002 Data Book	Feb 2002
03	<ul style="list-style-type: none">• Part number changes - see page 14 for additional information• Clarified the Test Conditions for V_{DD} Read Current parameter in Table 4 on page 5<ul style="list-style-type: none">– Address input = V_{ILT}/V_{IHT}– $CE\#=OE\#=V_{ILT}$	Mar 2003
04	<ul style="list-style-type: none">• 2004 Data Book• Added non-Pb MPNs and removed footnote (See page 14)	Nov 2003
05	<ul style="list-style-type: none">• Removed 90 ns parts, related footnote, and MPNs (See page 14)• Added 70 ns parts and MPNs for the PH package• Changed Byte-Program time from 10 μs to 15 μs• Updated chip program times• Separated Supervoltage Current for A_9 and $OE\#$ in Table 5 on page 6	May 2004
06	<ul style="list-style-type: none">• Added non-Pb 32-PDIP MPNs for 1, 2, and 4 Mbit devices• Clarified the solder temperature profile under “Absolute Maximum Stress Ratings” on page 5	Dec 2004